

BASIC COMPUTER ORGANIZATION AND DESIGN

- **Instruction Codes**
- **Computer Registers**
- **Computer Instructions**
- **Timing and Control**
- **Instruction Cycle**
- **Memory Reference Instructions**
- **Input-Output and Interrupt**
- **Complete Computer Description**
- **Design of Basic Computer**
- **Design of Accumulator Logic**

INTRODUCTION

- **Every different processor has its own design**
(different registers, buses, micro-operations, machine instructions, etc)
- **Modern processor is a very complex device**
- **It contains**
 - Many registers
 - Multiple arithmetic units, for both integer and floating point calculations
 - The ability to pipeline several consecutive instructions to speed execution
 - Etc.
- **However, to understand how processors work, use a simplified processor model**
- **This is similar to what real processors were like ~25 years ago**

THE BASIC COMPUTER

- The Basic Computer has two components, a processor and memory
- The memory has 4096 words in it
 - $4096 = 2^{12}$, so it takes 12 bits to select a word in memory
- Each word is 16 bits long

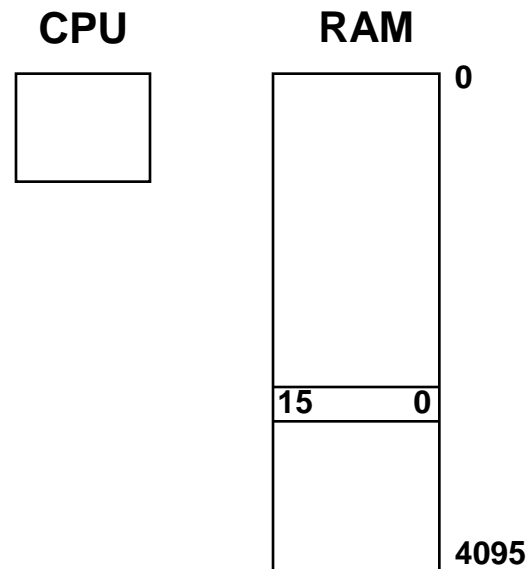

INSTRUCTIONS

- **Program**
 - A sequence of (machine) instructions
- **(Machine) Instruction**
 - A group of bits that tell the computer to *perform a specific operation* (a sequence of micro-operation)
- The instructions of a program, along with any needed data are stored in memory
- The CPU reads the next instruction from memory
- It is placed in an *Instruction Register (IR)*
- Control circuitry in control unit then translates the instruction into the sequence of microoperations necessary to implement it

INSTRUCTION FORMAT

- A computer instruction is often divided into two parts
 - An *opcode* (Operation Code) that specifies the operation for that instruction
 - An *address* that specifies the registers and/or locations in memory to use for that operation
- In the Basic Computer, since the memory contains 4096 (= 2^{12}) words, we need 12 bits to specify which memory address this instruction will use
- In the Basic Computer, bit 15 of the instruction specifies the *addressing mode* (0: direct addressing, 1: indirect addressing)
- Since the memory words, and hence the instructions, are 16 bits long, that leaves 3 bits for the instruction's opcode

Instruction Format

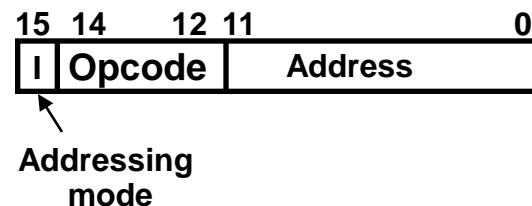

ADDRESSING MODES

- The address field of an instruction can represent either
 - Direct address: the address in memory of the data to use (the address of the operand), or
 - Indirect address: the address in memory of the address in memory of the data to use

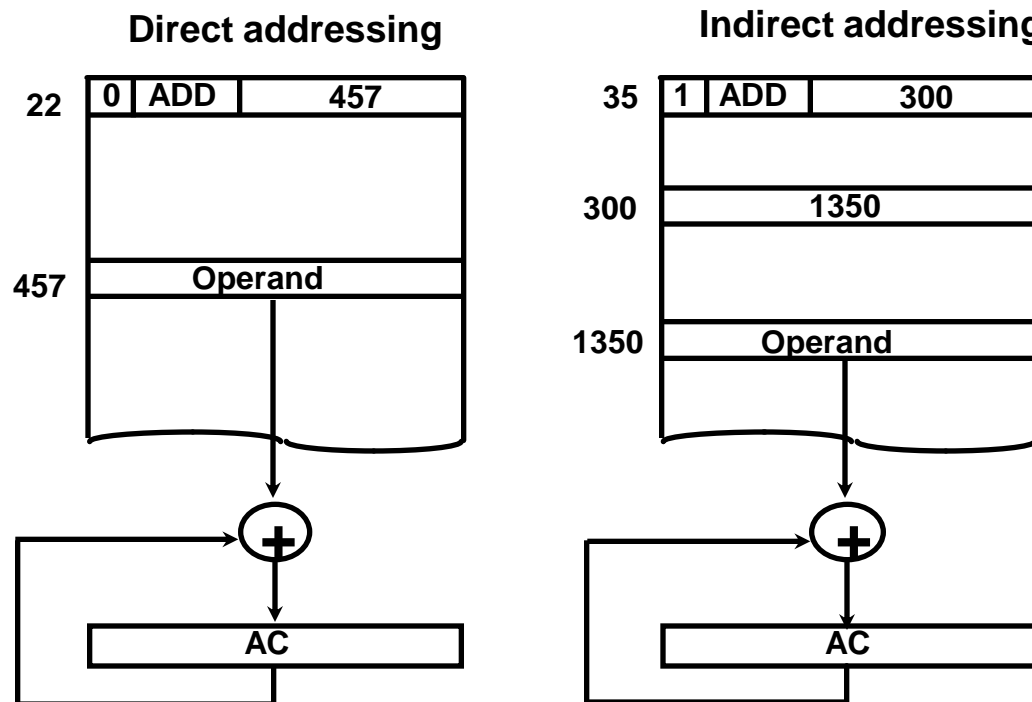

- **Effective Address (EA)**

- The address, that can be directly used without modification to access an operand for a computation-type instruction, or as the target address for a branch-type instruction

PROCESSOR REGISTERS

- A processor has many registers to hold instructions, addresses, data, etc
- The processor has a register, the *Program Counter (PC)* that holds the memory address of the next instruction
 - Since the memory in the Basic Computer only has 4096 locations, the PC only needs 12 bits
- In a direct or indirect addressing, the processor needs to keep track of what locations in memory it is addressing: The *Address Register (AR)* is used for this
 - The AR is a 12 bit register in the Basic Computer
- When an operand is found, using either direct or indirect addressing, it is placed in the *Data Register (DR)*. The processor then uses this value as data for its operation
- The Basic Computer has a single *general purpose register* – the *Accumulator (AC)*

PROCESSOR REGISTERS

- The significance of a general purpose register is that it can be used for loading operands and storing results
 - e.g. load AC with the contents of a specific memory location; store the contents of AC into a specified memory location
- Often a processor will need a scratch register to store intermediate results or other temporary data; in the Basic Computer this is the *Temporary Register (TR)*
- The Basic Computer uses a very simple model of input/output (I/O) operations
 - Input devices are considered to send 8 bits of character data to the processor
 - The processor can send 8 bits of character data to output devices
- The *Input Register (INPR)* holds an 8 bit character gotten from an input device
- The *Output Register (OUTR)* holds an 8 bit character to be send to an output device

BASIC COMPUTER REGISTERS

Registers in the Basic Computer

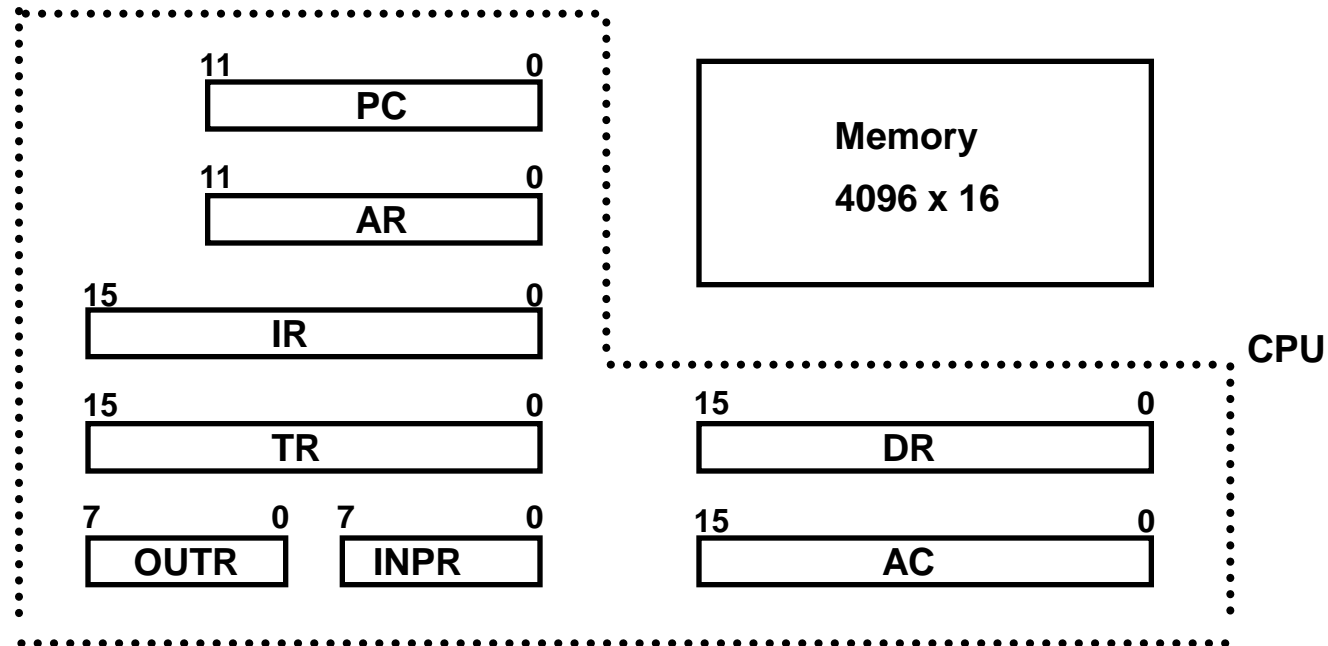

List of Registers

DR	16	Data Register	Holds memory operand
AR	12	Address Register	Holds address for memory
AC	16	Accumulator	Processor register
IR	16	Instruction Register	Holds instruction code
PC	12	Program Counter	Holds address of instruction
TR	16	Temporary Register	Holds temporary data
INPR	8	Input Register	Holds input character
OUTR	8	Output Register	Holds output character

COMMON BUS SYSTEM

- **The registers in the Basic Computer are connected using a bus**
- **This gives a savings in circuitry over complete connections between registers**

COMMON BUS SYSTEM

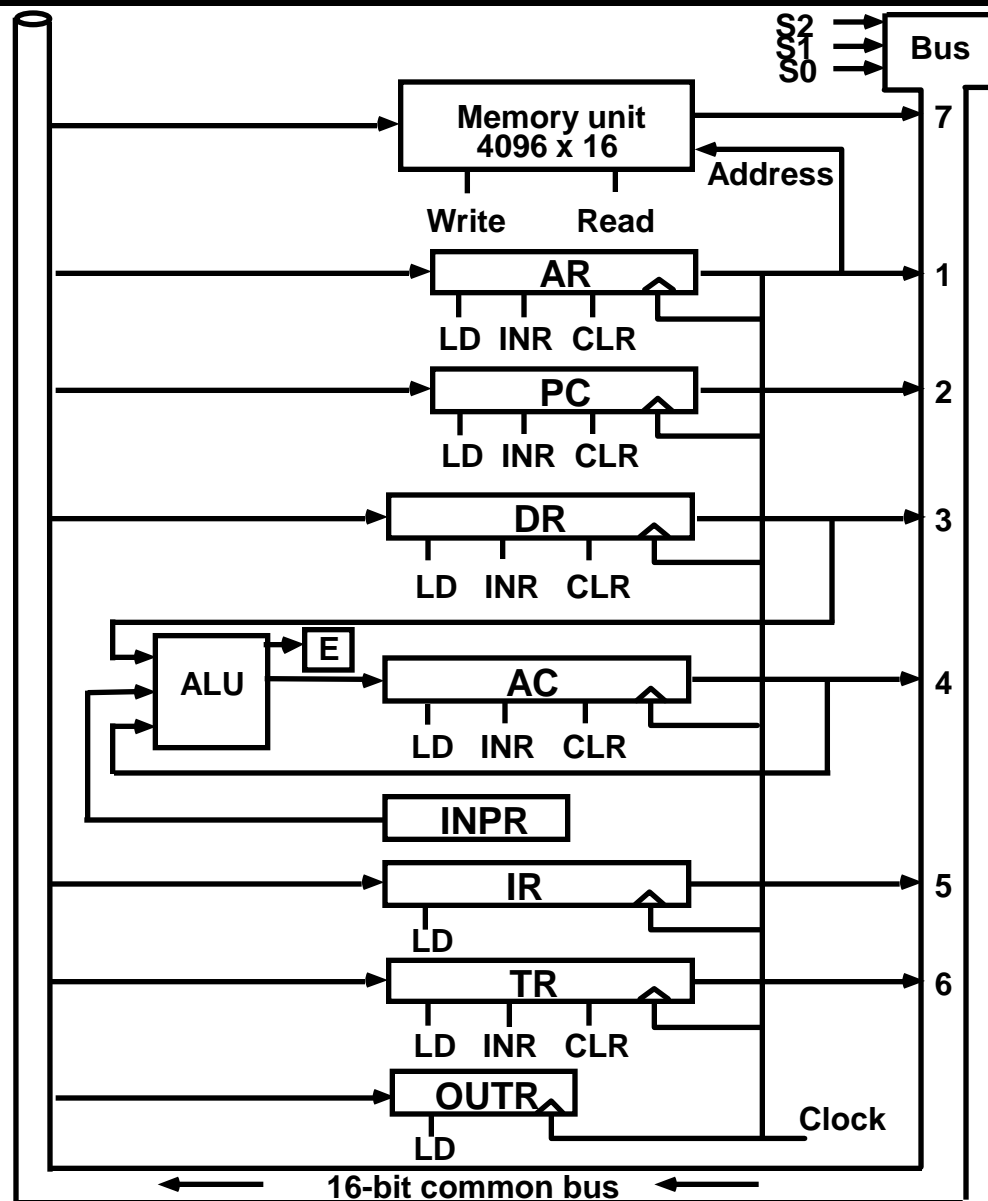

COMMON BUS SYSTEM

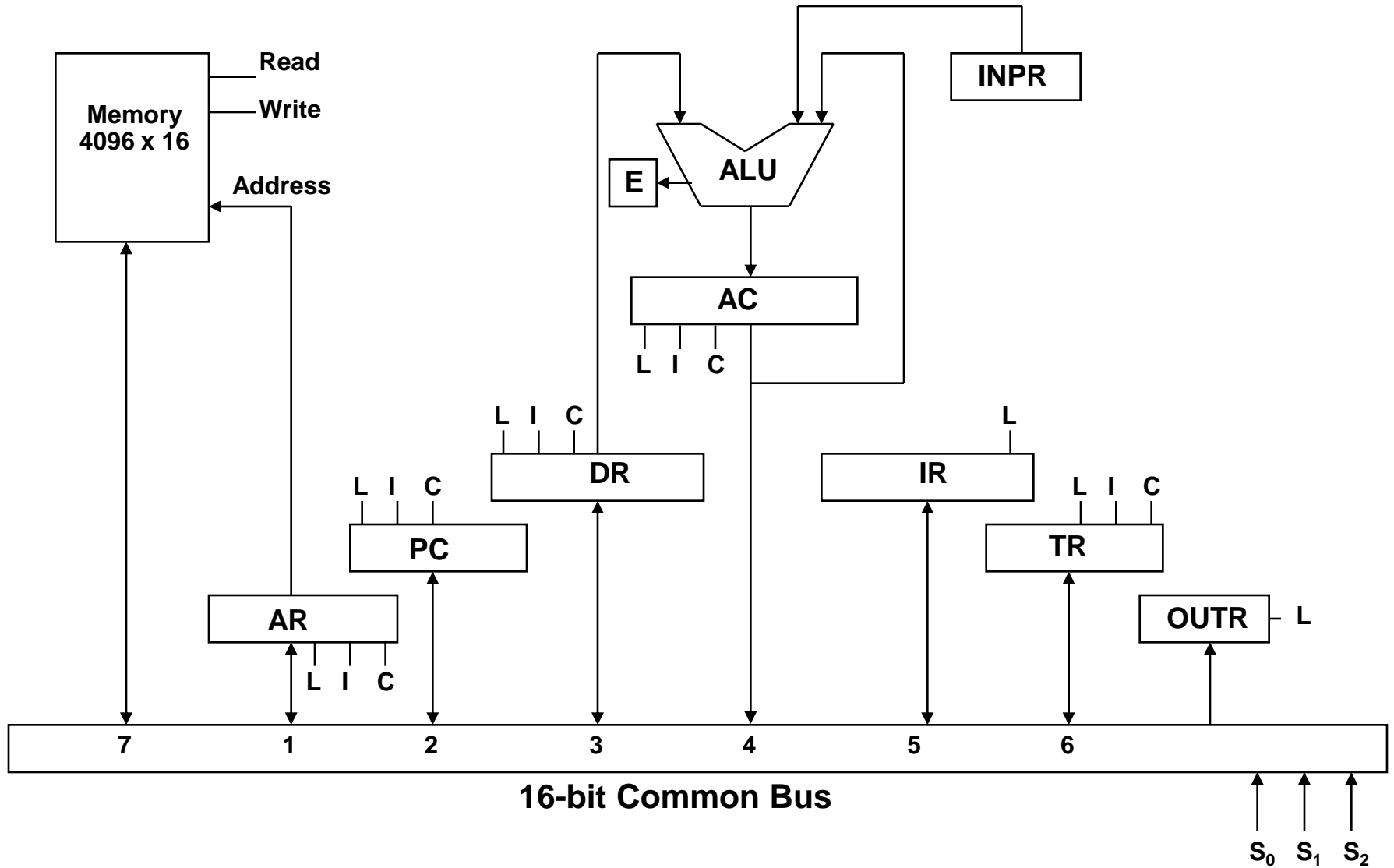

COMMON BUS SYSTEM

- Three control lines, S_2 , S_1 , and S_0 control which register the bus selects as its input

S_2	S_1	S_0	Register
0	0	0	X
0	0	1	AR
0	1	0	PC
0	1	1	DR
1	0	0	AC
1	0	1	IR
1	1	0	TR
1	1	1	Memory

- Either one of the registers will have its load signal activated, or the memory will have its read signal activated
 - Will determine where the data from the bus gets loaded
- The 12-bit registers, AR and PC, have 0's loaded onto the bus in the high order 4 bit positions
- When the 8-bit register OTR is loaded from the bus, the data comes from the low order 8 bits on the bus

BASIC COMPUTER INSTRUCTIONS

• Basic Computer Instruction Format

Memory-Reference Instructions (OP-code = 000 ~ 110)



Register-Reference Instructions (OP-code = 111, I = 0)



Input-Output Instructions (OP-code = 111, I = 1)

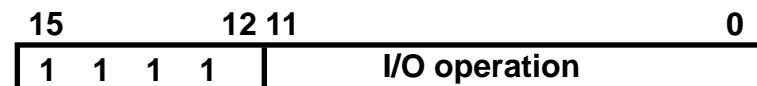

BASIC COMPUTER INSTRUCTIONS

Symbol	Hex Code		Description
	I = 0	I = 1	
AND	0xxx	8xxx	AND memory word to AC
ADD	1xxx	9xxx	Add memory word to AC
LDA	2xxx	Axxx	Load AC from memory
STA	3xxx	Bxxx	Store content of AC into memory
BUN	4xxx	Cxxx	Branch unconditionally
BSA	5xxx	Dxxx	Branch and save return address
ISZ	6xxx	Exxx	Increment and skip if zero
CLA	7800		Clear AC
CLE	7400		Clear E
CMA	7200		Complement AC
CME	7100		Complement E
CIR	7080		Circulate right AC and E
CIL	7040		Circulate left AC and E
INC	7020		Increment AC
SPA	7010		Skip next instr. if AC is positive
SNA	7008		Skip next instr. if AC is negative
SZA	7004		Skip next instr. if AC is zero
SZE	7002		Skip next instr. if E is zero
HLT	7001		Halt computer
INP	F800		Input character to AC
OUT	F400		Output character from AC
SKI	F200		Skip on input flag
SKO	F100		Skip on output flag
ION	F080		Interrupt on
IOF	F040		Interrupt off

INSTRUCTION SET COMPLETENESS

Set of instructions using which user can construct machine language programs to evaluate any computable function.

- **Instruction Types**

- Functional Instructions**

- Arithmetic, logic, and shift instructions
 - ADD, CMA, INC, CIR, CIL, AND, CLA

- Transfer Instructions**

- Data transfers between the main memory and the processor registers
 - LDA, STA

- Control Instructions**

- Program sequencing and control
 - BUN, BSA, ISZ

- Input/Output Instructions**

- Input and output
 - INP, OUT

CONTROL UNIT

- Control unit (CU) of a processor translates from machine instructions to the control signals (for the microoperations) that implement them
- Control units are implemented in one of two ways
- **Hardwired Control**
 - CU is made up of **sequential and combinational** circuits to generate the control signals
- **Microprogrammed Control**
 - A **control memory** on the processor contains microprograms that activate the necessary control signals
- We will consider a **hardwired implementation** of the control unit for the Basic Computer

TIMING AND CONTROL

Control unit of Basic Computer

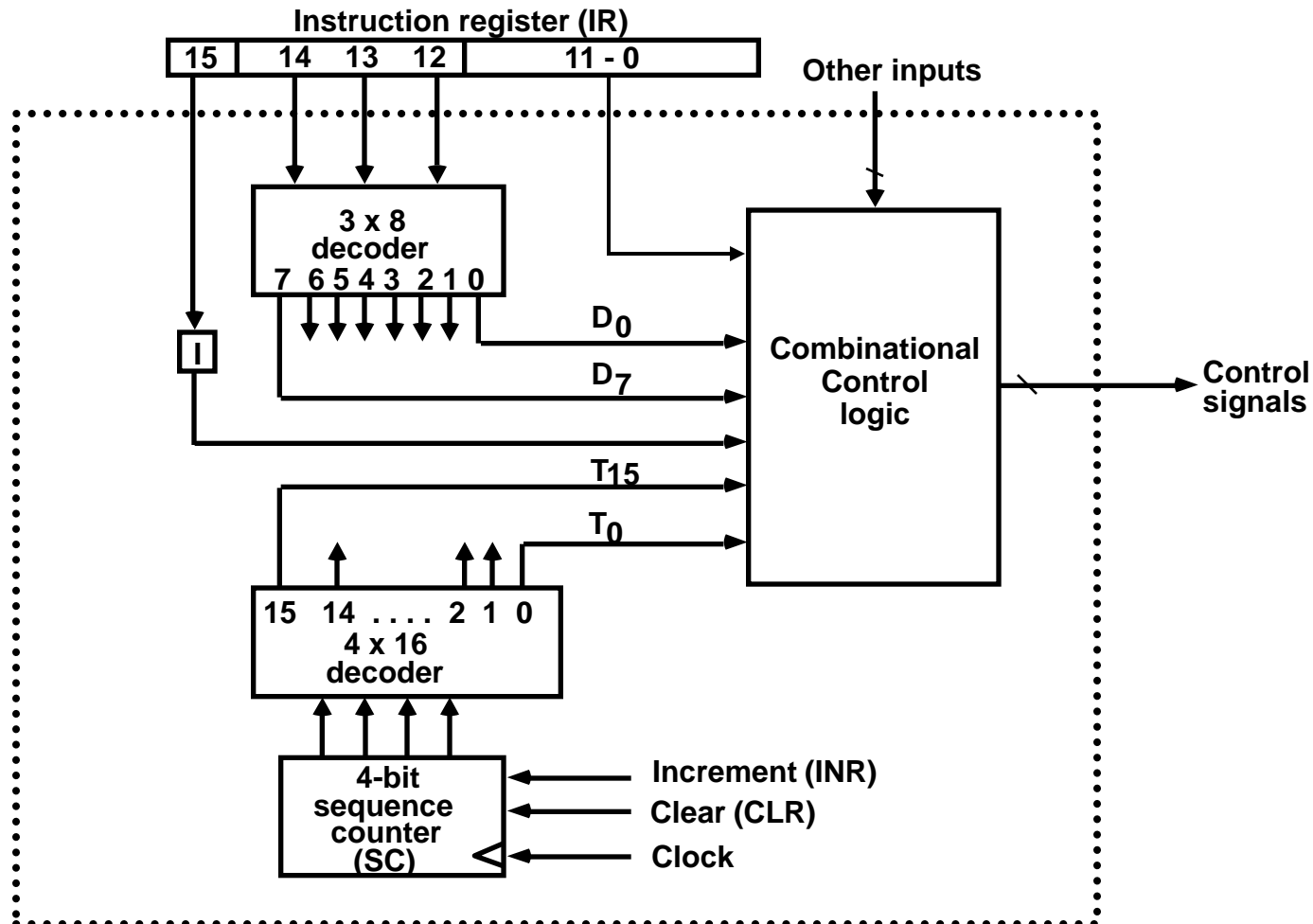

TIMING SIGNALS

- Generated by 4-bit sequence counter and 4×16 decoder
- The SC can be incremented or cleared.
- Example: $T_0, T_1, T_2, T_3, T_4, T_0, T_1, \dots$
Assume: At time T_4 , SC is cleared to 0 if decoder output D3 is active.

$D_3 T_4: SC \leftarrow 0$

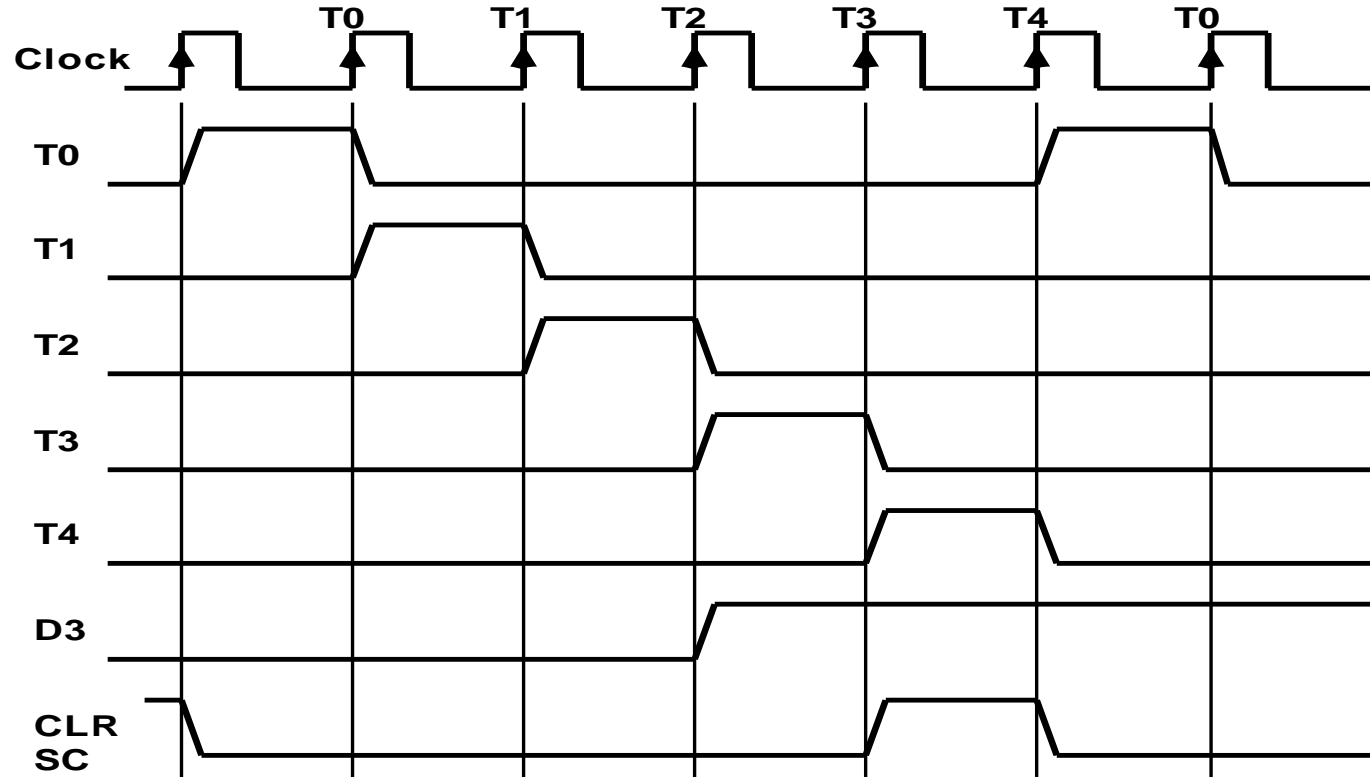

INSTRUCTION CYCLE

- In Basic Computer, a machine instruction is executed in the following cycle:
 1. Fetch an instruction from memory
 2. Decode the instruction and calculate effective address (EA)
 3. Read the EA from memory if the instruction has an indirect address (Fetch operand)
- Execute the instruction
- After an instruction is executed, the cycle starts again at step 1, for the next instruction
- **Note:** Every different processor has its own (different) instruction cycle

FETCH and DECODE

• Fetch and Decode

T0: $AR \leftarrow PC$ ($S_0S_1S_2=010$, $T_0=1$)

T1: $IR \leftarrow M[AR]$, $PC \leftarrow PC + 1$ ($S_0S_1S_2=111$, $T_1=1$)

T2: $D_0, \dots, D_7 \leftarrow \text{Decode } IR(12-14)$, $AR \leftarrow IR(0-11)$, $I \leftarrow IR(15)$

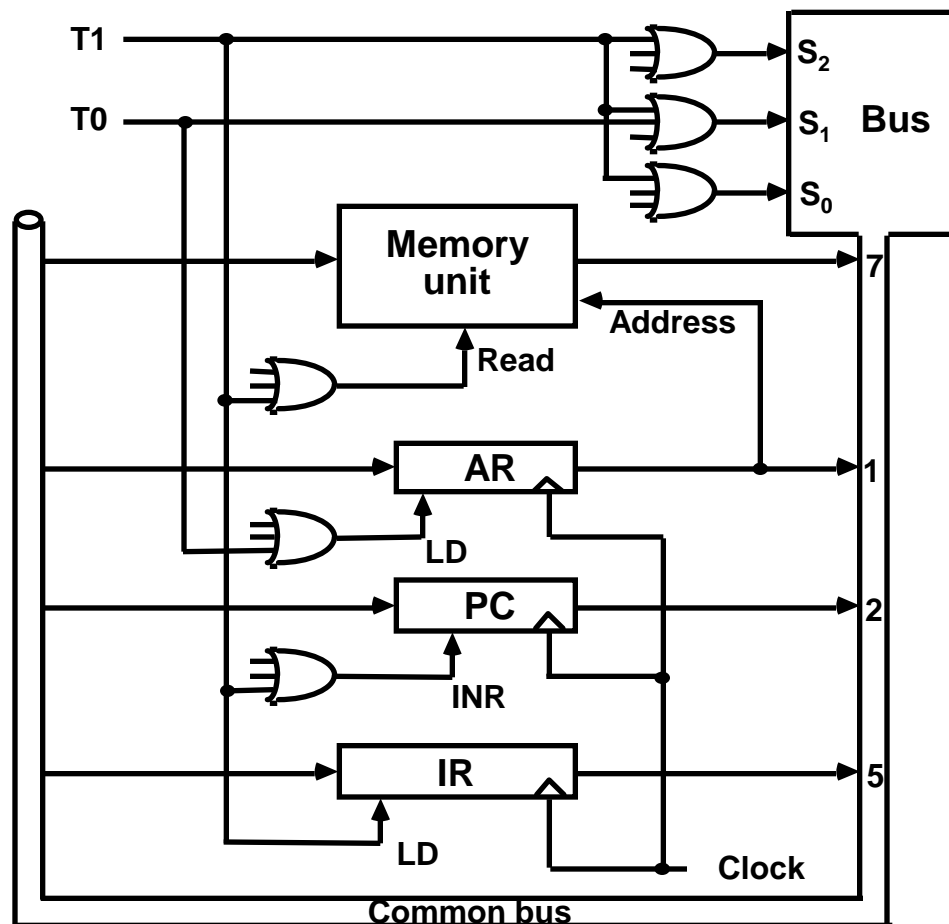

DETERMINE THE TYPE OF INSTRUCTION

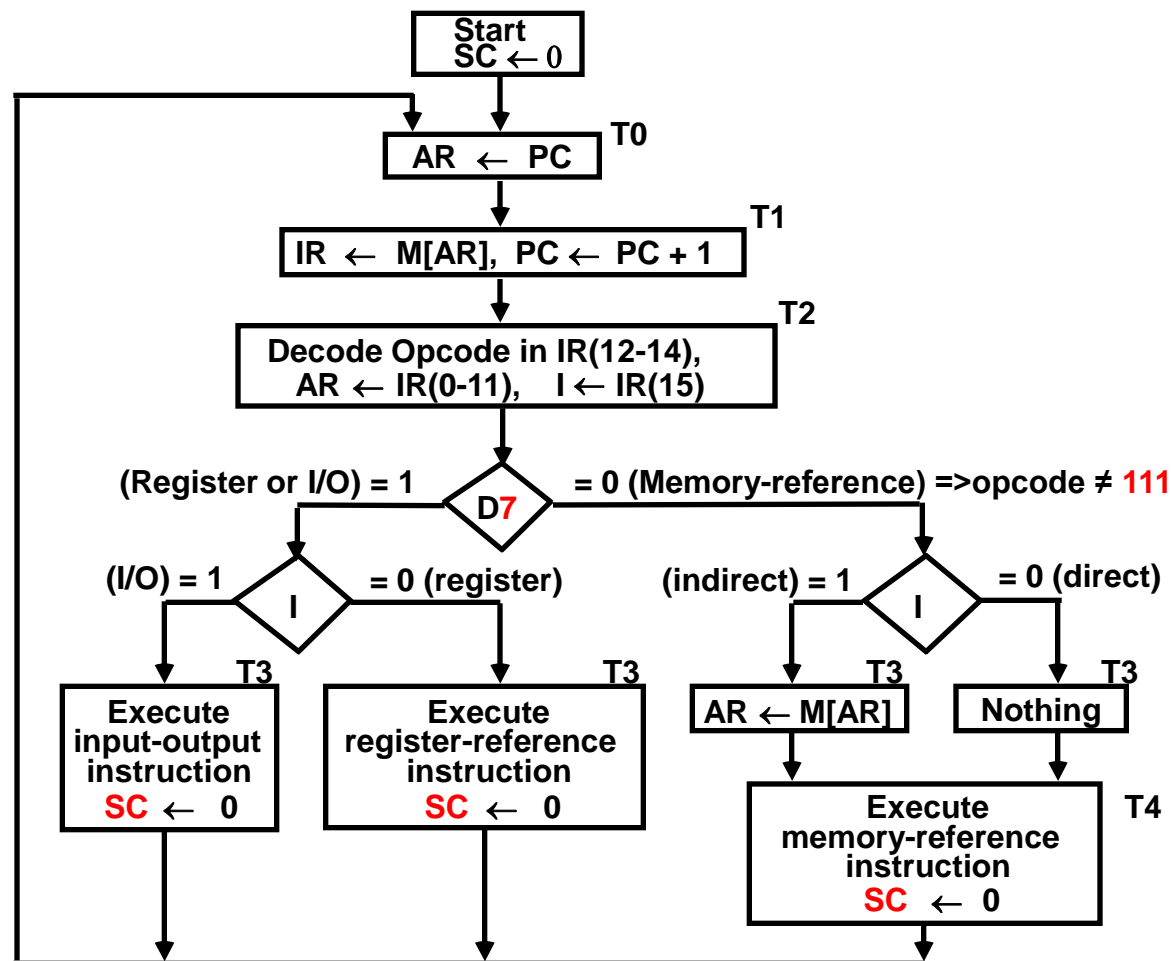

D'7IT3: AR ← M[AR]
 D'7I'T3: Nothing
 D7I'T3: Execute a register-reference instr.
 D7IT3: Execute an input-output instr.

REGISTER REFERENCE INSTRUCTIONS

Register Reference Instructions are identified when

- $D_7 = 1, I = 0$
- Register Ref. Instr. is specified in $b_0 \sim b_{11}$ of IR
- Execution starts with timing signal T_3

$r = D_7 I' T_3 \Rightarrow$ Register Reference Instruction

$B_i = IR(i), i=0,1,2,\dots,11$

	r:	$SC \leftarrow 0$
CLA	rB_{11} :	$AC \leftarrow 0$
CLE	rB_{10} :	$E \leftarrow 0$
CMA	rB_9 :	$AC \leftarrow AC'$
CME	rB_8 :	$E \leftarrow E'$
CIR	rB_7 :	$AC \leftarrow shr AC, AC(15) \leftarrow E, E \leftarrow AC(0)$
CIL	rB_6 :	$AC \leftarrow shl AC, AC(0) \leftarrow E, E \leftarrow AC(15)$
INC	rB_5 :	$AC \leftarrow AC + 1$
SPA	rB_4 :	if $(AC(15) = 0)$ then $(PC \leftarrow PC+1)$
SNA	rB_3 :	if $(AC(15) = 1)$ then $(PC \leftarrow PC+1)$
SZA	rB_2 :	if $(AC = 0)$ then $(PC \leftarrow PC+1)$
SZE	rB_1 :	if $(E = 0)$ then $(PC \leftarrow PC+1)$
HLT	rB_0 :	$S \leftarrow 0$ (S is a start-stop flip-flop)

MEMORY REFERENCE INSTRUCTIONS

Symbol	Operation Decoder	Symbolic Description
AND	D ₀	$AC \leftarrow AC \wedge M[AR]$
ADD	D ₁	$AC \leftarrow AC + M[AR], E \leftarrow C_{out}$
LDA	D ₂	$AC \leftarrow M[AR]$
STA	D ₃	$M[AR] \leftarrow AC$
BUN	D ₄	$PC \leftarrow AR$
BSA	D ₅	$M[AR] \leftarrow PC, PC \leftarrow AR + 1$
ISZ	D ₆	$M[AR] \leftarrow M[AR] + 1, \text{ if } M[AR] + 1 = 0 \text{ then } PC \leftarrow PC + 1$

- The effective address of the instruction is in AR and was placed there during timing signal T₂ when I = 0, or during timing signal T₃ when I = 1
- Memory cycle is assumed to be short enough to complete in a CPU cycle
- The execution of MR instruction starts with T₄

AND to AC

D₀T₄: DR ← M[AR] Read operand

D₀T₅: AC ← AC ∧ DR, SC ← 0 AND with AC

ADD to AC

D₁T₄: DR ← M[AR] Read operand

D₁T₅: AC ← AC + DR, E ← C_{out}, SC ← 0 Add to AC and store carry in E

MEMORY REFERENCE INSTRUCTIONS

LDA: Load to AC

D_2T_4 : $DR \leftarrow M[AR]$

D_2T_5 : $AC \leftarrow DR$, $SC \leftarrow 0$

STA: Store AC

D_3T_4 : $M[AR] \leftarrow AC$, $SC \leftarrow 0$

BUN: Branch Unconditionally

D_4T_4 : $PC \leftarrow AR$, $SC \leftarrow 0$

BSA: Branch and Save Return Address

Memory, PC, AR at time T_4

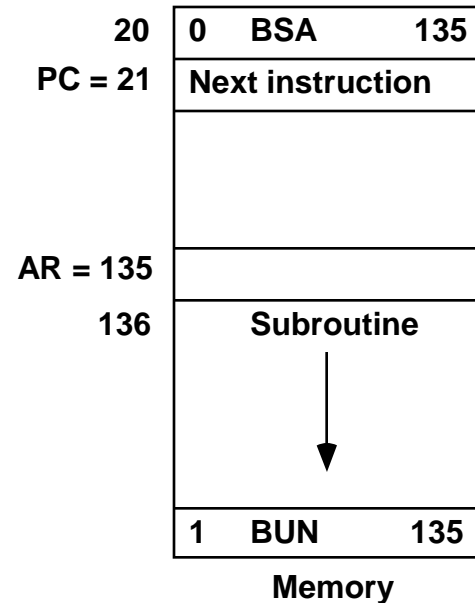

Memory, PC after execution

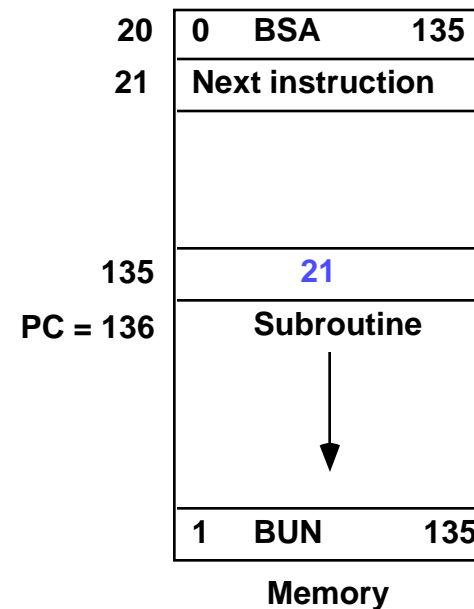

MEMORY REFERENCE INSTRUCTIONS

BSA:

D_5T_4 : $M[AR] \leftarrow PC, AR \leftarrow AR + 1$

D_5T_5 : $PC \leftarrow AR, SC \leftarrow 0$

ISZ: Increment and Skip-if-Zero

D_6T_4 : $DR \leftarrow M[AR]$

D_6T_5 : $DR \leftarrow DR + 1$

D_6T_4 : $M[AR] \leftarrow DR, \text{ if } (DR = 0) \text{ then } (PC \leftarrow PC + 1), SC \leftarrow 0$

FLOWCHART FOR MEMORY REFERENCE INSTRUCTIONS

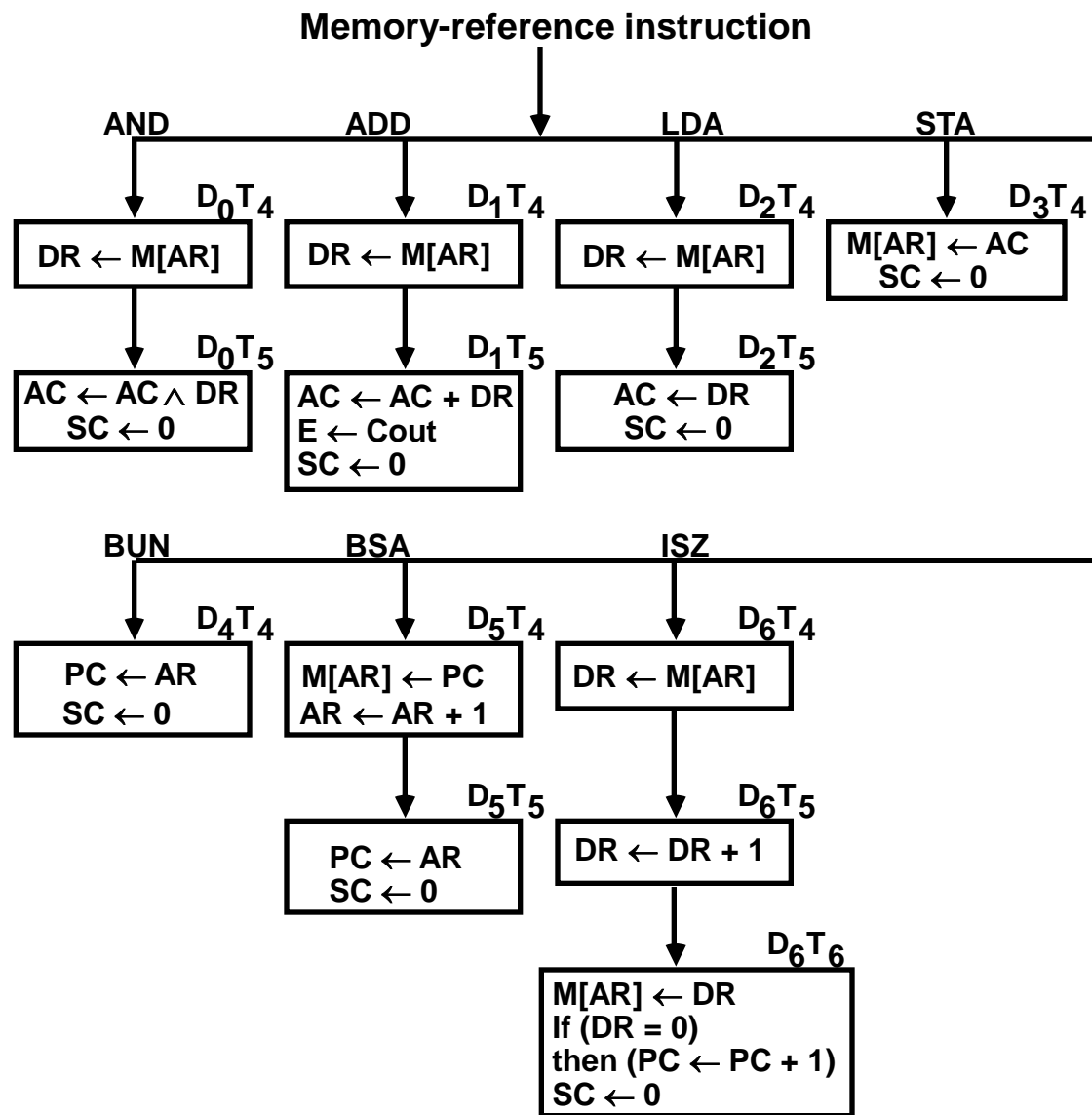

INPUT-OUTPUT AND INTERRUPT

A Terminal with a keyboard and a Printer

• Input-Output Configuration

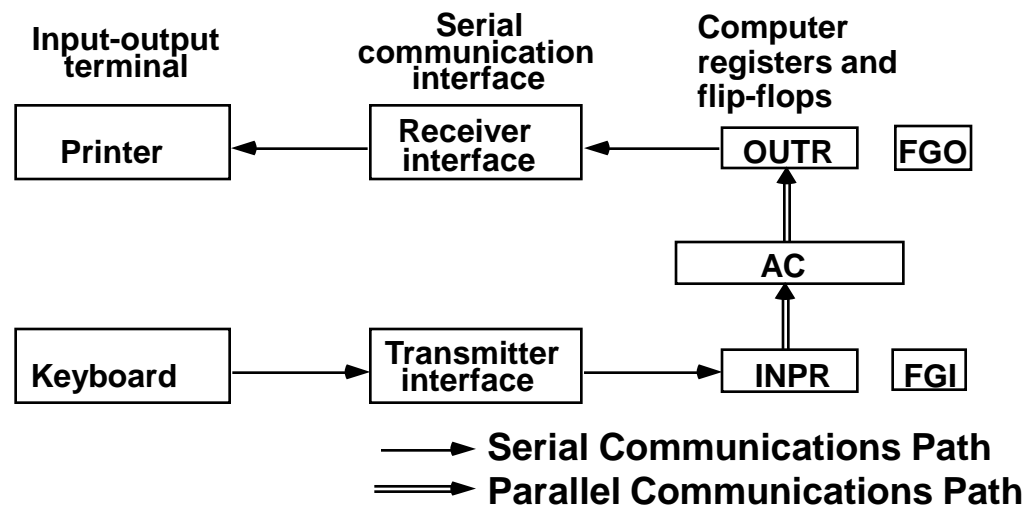

INPR Input register - 8 bits
OUTR Output register - 8 bits
FGI Input flag - 1 bit
FGO Output flag - 1 bit
IEN Interrupt enable - 1 bit

- The terminal sends and receives serial information
- The serial info. from the keyboard is shifted into INPR
- The serial info. for the printer is stored in the OTR
- INPR and OTR communicate with the terminal serially and with the AC in parallel.
- The flags are needed to *synchronize* the timing difference between I/O device and the computer

PROGRAM CONTROLLED DATA TRANSFER

-- CPU --

```
loop: If FGI = 0 goto loop
      AC ← INPR, FGI ← 0
```

```
/* Output */      /* Initially FGO = 1 */
loop: If FGO = 0 goto loop
      OUTR ← AC, FGO ← 0
```

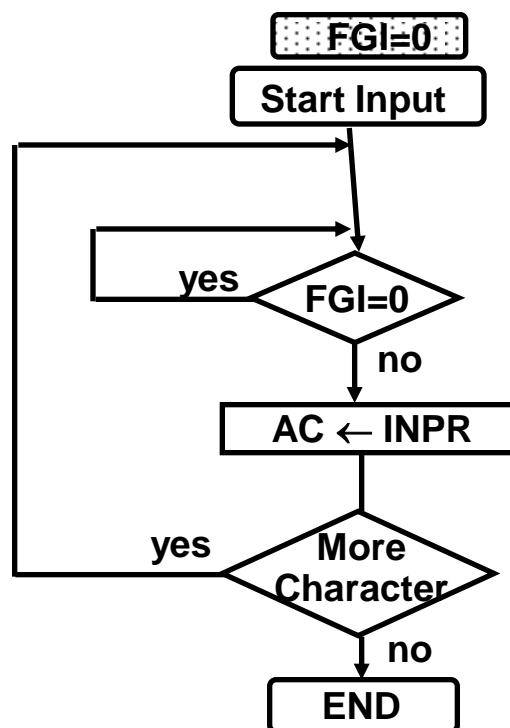

-- I/O Device --

```
/* Input */      /* Initially FGI = 0 */
loop: If FGI = 1 goto loop
      INPR ← new data, FGI ← 1
```

```
loop: If FGO = 1 goto loop
      consume OUTR, FGO ← 1
```

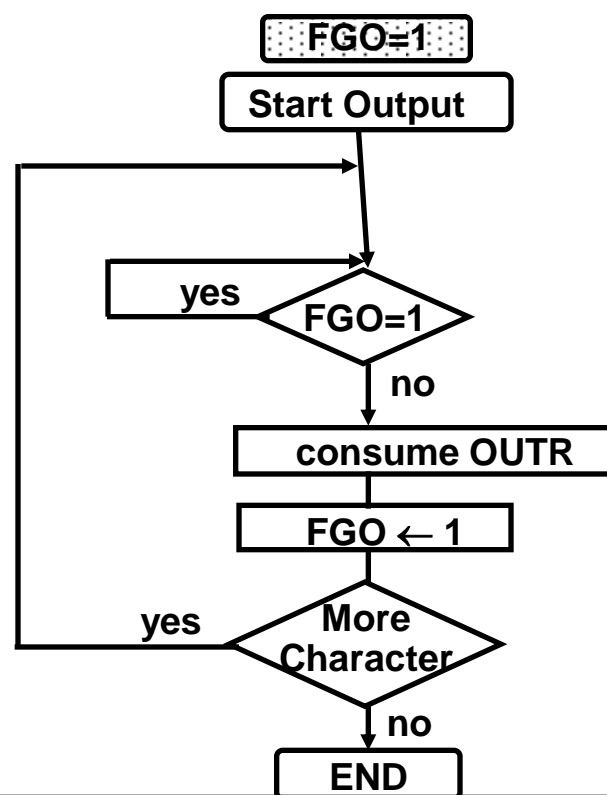

INPUT-OUTPUT INSTRUCTIONS

CPU Side

$D_7IT_3 = p$

$IR(i) = B_i, i = 6, \dots, 11$

	p:	$SC \leftarrow 0$	Clear SC
INP	pB_{11}:	$AC(0-7) \leftarrow INPR, FGI \leftarrow 0$	Input char. to AC
OUT	pB_{10}:	$OUTR \leftarrow AC(0-7), FGO \leftarrow 0$	Output char. from AC
SKI	pB_9:	if($FGI = 1$) then ($PC \leftarrow PC + 1$)	Skip on input flag
SKO	pB_8:	if($FGO = 1$) then ($PC \leftarrow PC + 1$)	Skip on output flag
ION	pB_7:	$IEN \leftarrow 1$	Interrupt enable on
IOF	pB_6:	$IEN \leftarrow 0$	Interrupt enable off

PROGRAM-CONTROLLED INPUT/OUTPUT

- Program-controlled I/O
 - Continuous CPU involvement
I/O takes valuable CPU time
 - CPU slowed down to I/O speed
 - Simple
 - Least hardware

Input

```
LOOP    SKI  DEV
        BUN  LOOP
        INP  DEV
```

Output

```
LOOP    LDA  DATA
        SKO  DEV
        BUN  LOOP
        OUT  DEV
```

INTERRUPT INITIATED INPUT/OUTPUT

- Open communication only when some data has to be passed --> *interrupt*.
- The I/O interface, instead of the CPU, monitors the I/O device.
- When the interface finds that the I/O device is ready for data transfer, it generates an interrupt request to the CPU
- Upon detecting an interrupt, the CPU stops momentarily the task it is doing, branches to the service routine to process the data transfer, and then returns to the task it was performing.

* IEN (Interrupt-enable flip-flop)

- can be set and cleared by instructions
- when cleared, the computer cannot be interrupted

FLOWCHART FOR INTERRUPT CYCLE

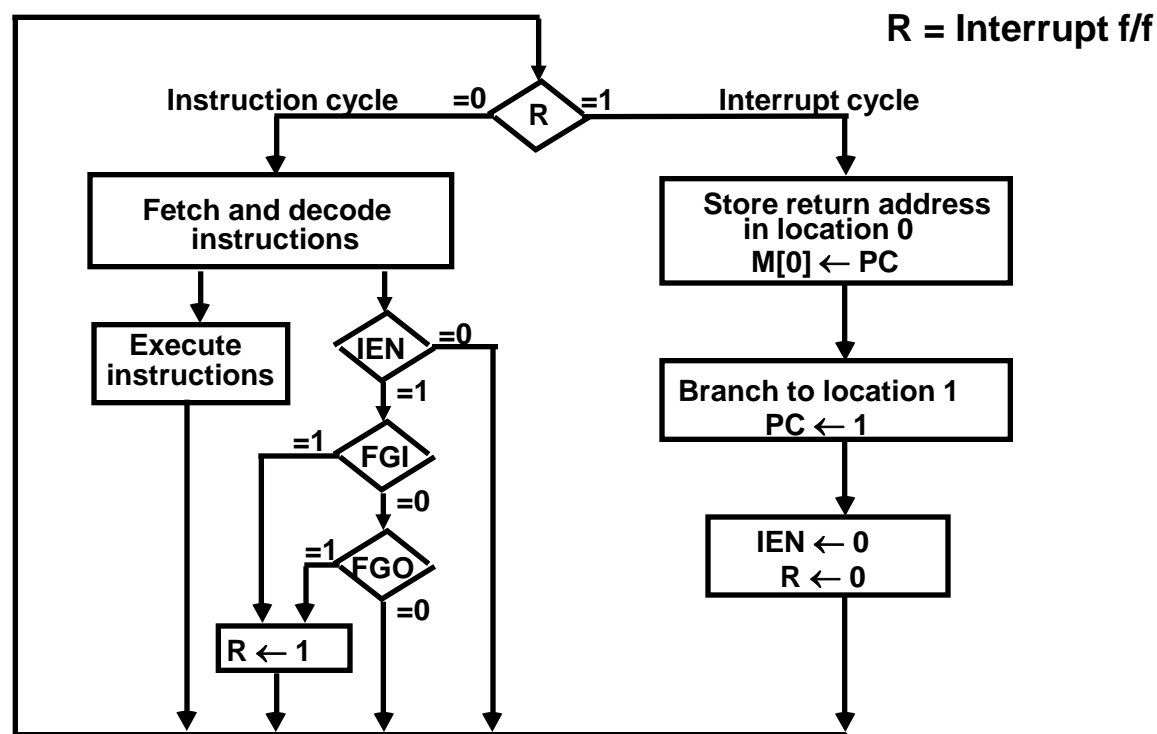

- The interrupt cycle is a HW implementation of a branch and save return address operation.
- At the beginning of the next instruction cycle, the instruction that is read from memory is in address 1.
- At memory address 1, the programmer must store a branch instruction that sends the control to an interrupt service routine
- The instruction that returns the control to the original program is "indirect BUN 0"

REGISTER TRANSFER OPERATIONS IN INTERRUPT CYCLE

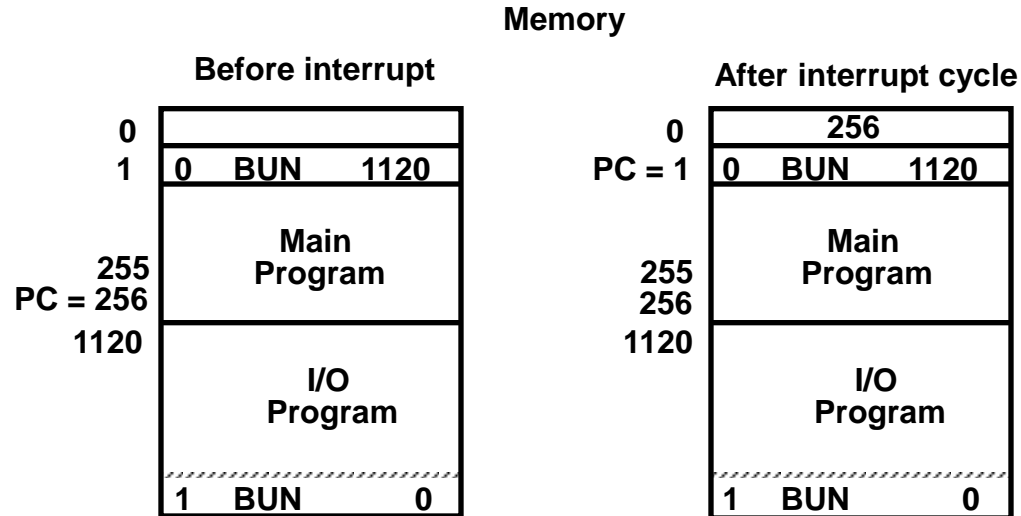

Register Transfer Statements for Interrupt Cycle

$$\begin{aligned}
 & - R \text{ F/F} \leftarrow 1 \quad \text{if } IEN (FGI + FGO) T_0' T_1' T_2' \\
 & \quad \Leftrightarrow T_0' T_1' T_2' (IEN)(FGI + FGO): R \leftarrow 1
 \end{aligned}$$

- The fetch and decode phases of the instruction cycle must be modified \rightarrow Replace T_0, T_1, T_2 with $R'T_0, R'T_1, R'T_2$
- The interrupt cycle :

$$RT_0: \quad AR \leftarrow 0, TR \leftarrow PC$$

$$RT_1: \quad M[AR] \leftarrow TR, PC \leftarrow 0$$

$$RT_2: \quad PC \leftarrow PC + 1, IEN \leftarrow 0, R \leftarrow 0, SC \leftarrow 0$$

FURTHER QUESTIONS ON INTERRUPT

How can the CPU recognize the device requesting an interrupt ?

Since different devices are likely to require different interrupt service routines, how can the CPU obtain the starting address of the appropriate routine in each case ?

Should any device be allowed to interrupt the CPU while another interrupt is being serviced ?

How can the situation be handled when two or more interrupt requests occur simultaneously ?

COMPLETE COMPUTER DESCRIPTION

Microoperations

Fetch	R'T ₀ :	AR ← PC
	R'T ₁ :	IR ← M[AR], PC ← PC + 1
Decode	R'T ₂ :	D ₀ , ..., D ₇ ← Decode IR(12 ~ 14), AR ← IR(0 ~ 11), I ← IR(15)
Indirect Interrupt	D ₇ 'IT ₃ :	AR ← M[AR]
	T ₀ 'T ₁ 'T ₂ '(IEN)(FGI + FGO):	R ← 1
	RT ₀ :	AR ← 0, TR ← PC
	RT ₁ :	M[AR] ← TR, PC ← 0
	RT ₂ :	PC ← PC + 1, IEN ← 0, R ← 0, SC ← 0
Memory-Reference		
AND	D ₀ T ₄ :	DR ← M[AR]
	D ₀ T ₅ :	AC ← AC ∧ DR, SC ← 0
ADD	D ₁ T ₄ :	DR ← M[AR]
	D ₁ T ₅ :	AC ← AC + DR, E ← C _{out} , SC ← 0
LDA	D ₂ T ₄ :	DR ← M[AR]
	D ₂ T ₅ :	AC ← DR, SC ← 0
STA	D ₃ T ₄ :	M[AR] ← AC, SC ← 0
BUN	D ₄ T ₄ :	PC ← AR, SC ← 0
BSA	D ₅ T ₄ :	M[AR] ← PC, AR ← AR + 1
	D ₅ T ₅ :	PC ← AR, SC ← 0
ISZ	D ₆ T ₄ :	DR ← M[AR]
	D ₆ T ₅ :	DR ← DR + 1
	D ₆ T ₆ :	M[AR] ← DR, if(DR=0) then (PC ← PC + 1), SC ← 0

COMPLETE COMPUTER DESCRIPTION

Microoperations

Register-Reference

	$D_7I'T_3 = r$	(Common to all register-reference instr)
	$IR(i) = B_i$	($i = 0,1,2, \dots, 11$)
	$r:$	$SC \leftarrow 0$
CLA	$rB_{11}:$	$AC \leftarrow 0$
CLE	$rB_{10}:$	$E \leftarrow 0$
CMA	$rB_9:$	$AC \leftarrow AC'$
CME	$rB_8:$	$E \leftarrow E'$
CIR	$rB_7:$	$AC \leftarrow shr\ AC, AC(15) \leftarrow E, E \leftarrow AC(0)$
CIL	$rB_6:$	$AC \leftarrow shl\ AC, AC(0) \leftarrow E, E \leftarrow AC(15)$
INC	$rB_5:$	$AC \leftarrow AC + 1$
SPA	$rB_4:$	If($AC(15) = 0$) then ($PC \leftarrow PC + 1$)
SNA	$rB_3:$	If($AC(15) = 1$) then ($PC \leftarrow PC + 1$)
SZA	$rB_2:$	If($AC = 0$) then ($PC \leftarrow PC + 1$)
SZE	$rB_1:$	If($E = 0$) then ($PC \leftarrow PC + 1$)
HLT	$rB_0:$	$S \leftarrow 0$

Input-Output

	$D_7IT_3 = p$	(Common to all input-output instructions)
	$IR(i) = B_i$	($i = 6,7,8,9,10,11$)
	$p:$	$SC \leftarrow 0$
INP	$pB_{11}:$	$AC(0-7) \leftarrow INPR, FGI \leftarrow 0$
OUT	$pB_{10}:$	$OUTR \leftarrow AC(0-7), FGO \leftarrow 0$
SKI	$pB_9:$	If($FGI = 1$) then ($PC \leftarrow PC + 1$)
SKO	$pB_8:$	If($FGO = 1$) then ($PC \leftarrow PC + 1$)
ION	$pB_7:$	$IEN \leftarrow 1$
IOF	$pB_6:$	$IEN \leftarrow 0$

DESIGN OF BASIC COMPUTER(BC)

Hardware Components of BC

A memory unit: 4096 x 16.

Registers:

AR, PC, DR, AC, IR, TR, OUTR, INPR, and SC

Flip-Flops(Status):

I, S, E, R, IEN, FGI, and FGO

Decoders: a 3x8 Opcode decoder
a 4x16 timing decoder

Common bus: 16 bits

Control logic gates:

Adder and Logic circuit: Connected to AC

Control Logic Gates

- Input Controls of the nine registers
- Read and Write Controls of memory
- Set, Clear, or Complement Controls of the flip-flops
- S_2, S_1, S_0 Controls to select a register for the bus
- AC, and Adder and Logic circuit

CONTROL OF REGISTERS AND MEMORY

Address Register; AR

Scan all of the register transfer statements that change the content of AR:

$R'T_0$:	$AR \leftarrow PC$	$LD(AR)$
$R'T_2$:	$AR \leftarrow IR(0-11)$	$LD(AR)$
$D'I_3$:	$AR \leftarrow M[AR]$	$LD(AR)$
RT_0 :	$AR \leftarrow 0$	$CLR(AR)$
D_5T_4 :	$AR \leftarrow AR + 1$	$INR(AR)$



$LD(AR) = R'T_0 + R'T_2 + D'I_3$
$CLR(AR) = RT_0$
$INR(AR) = D_5T_4$

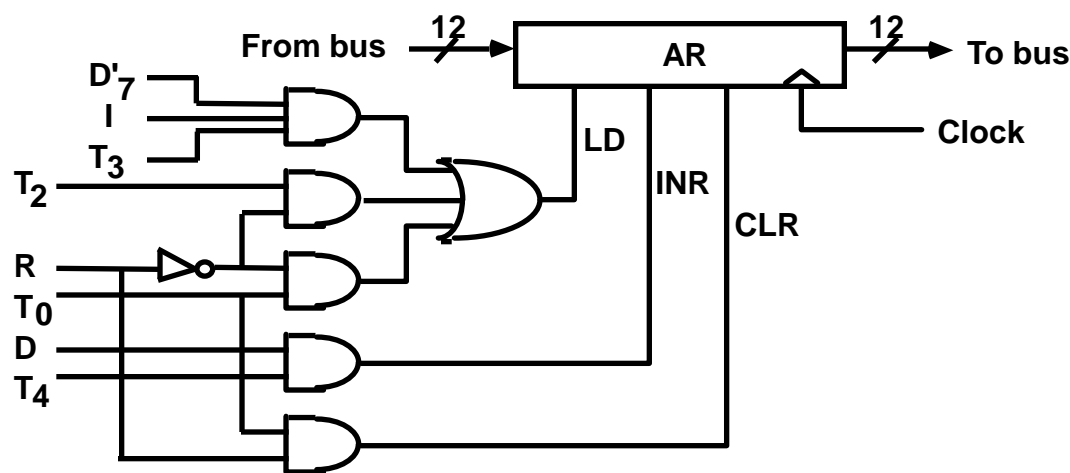

CONTROL OF FLAGS

IEN: Interrupt Enable Flag

pB_7 : IEN \leftarrow 1 (I/O Instruction)

pB_6 : IEN \leftarrow 0 (I/O Instruction)

RT_2 : IEN \leftarrow 0 (Interrupt)

$p = D_7IT_3$ (Input/Output Instruction)

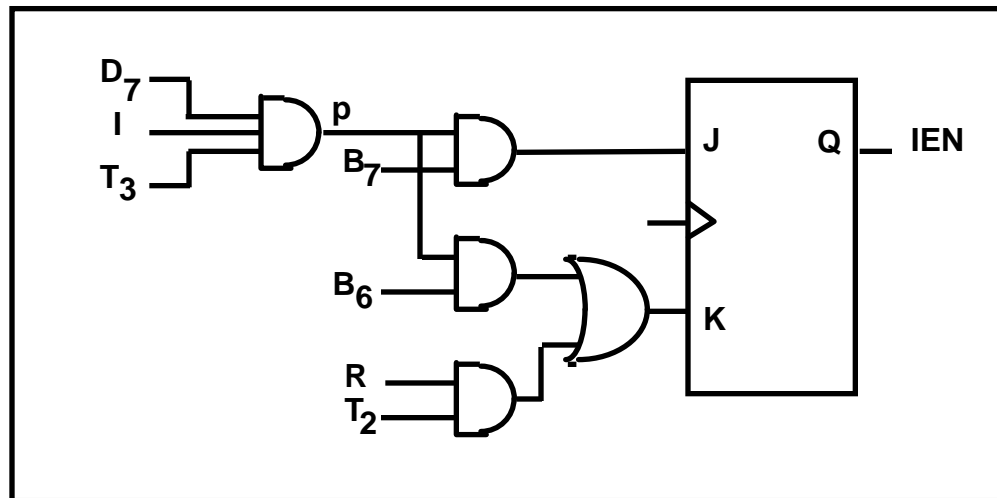

CONTROL OF COMMON BUS

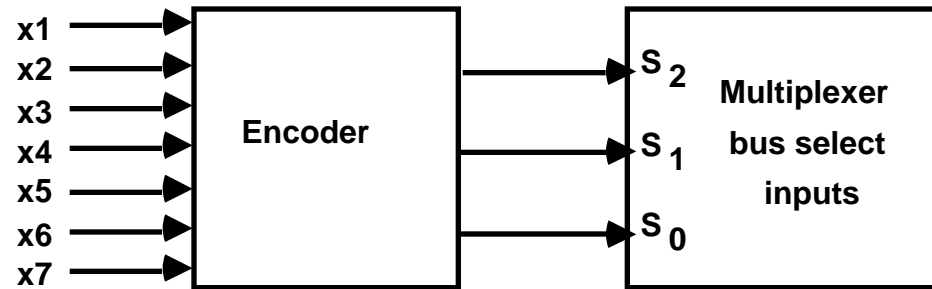

x_1	x_2	x_3	x_4	x_5	x_6	x_7	S_2	S_1	S_0	selected register
0	0	0	0	0	0	0	0	0	0	none
1	0	0	0	0	0	0	0	0	1	AR
0	1	0	0	0	0	0	0	1	0	PC
0	0	1	0	0	0	0	0	1	1	DR
0	0	0	1	0	0	0	1	0	0	AC
0	0	0	0	1	0	0	1	0	1	IR
0	0	0	0	0	1	0	1	1	0	TR
0	0	0	0	0	0	1	1	1	1	Memory

x_1 for placing AR onto bus

D_4T_4 : PC \leftarrow AR
 D_5T_5 : PC \leftarrow AR



$$x_1 = D_4T_4 + D_5T_5$$

DESIGN OF ACCUMULATOR LOGIC

Circuits associated with AC

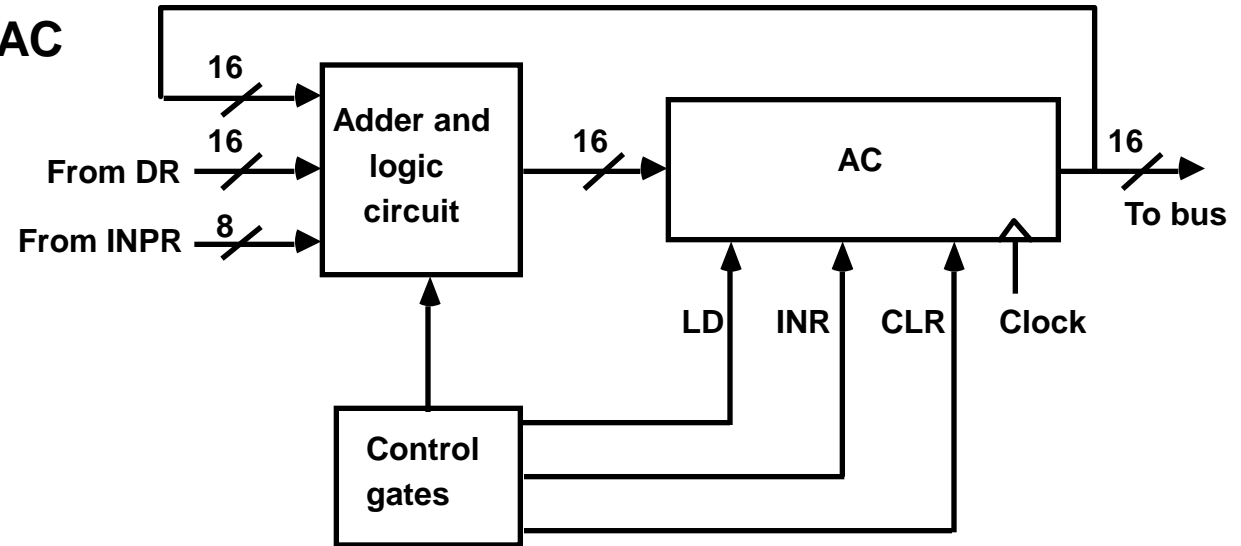

All the statements that change the content of AC

$D_0T_5:$	$AC \leftarrow AC \wedge DR$	AND with DR
$D_1T_5:$	$AC \leftarrow AC + DR$	Add with DR
$D_2T_5:$	$AC \leftarrow DR$	Transfer from DR
$pB_{11}:$	$AC(0-7) \leftarrow INPR$	Transfer from INPR
$rB_9:$	$AC \leftarrow AC'$	Complement
$rB_7:$	$AC \leftarrow shr\ AC, AC(15) \leftarrow E$	Shift right
$rB_6:$	$AC \leftarrow shl\ AC, AC(0) \leftarrow E$	Shift left
$rB_{11}:$	$AC \leftarrow 0$	Clear
$rB_5:$	$AC \leftarrow AC + 1$	Increment

CONTROL OF AC REGISTER

Gate structures for controlling the LD, INR, and CLR of AC

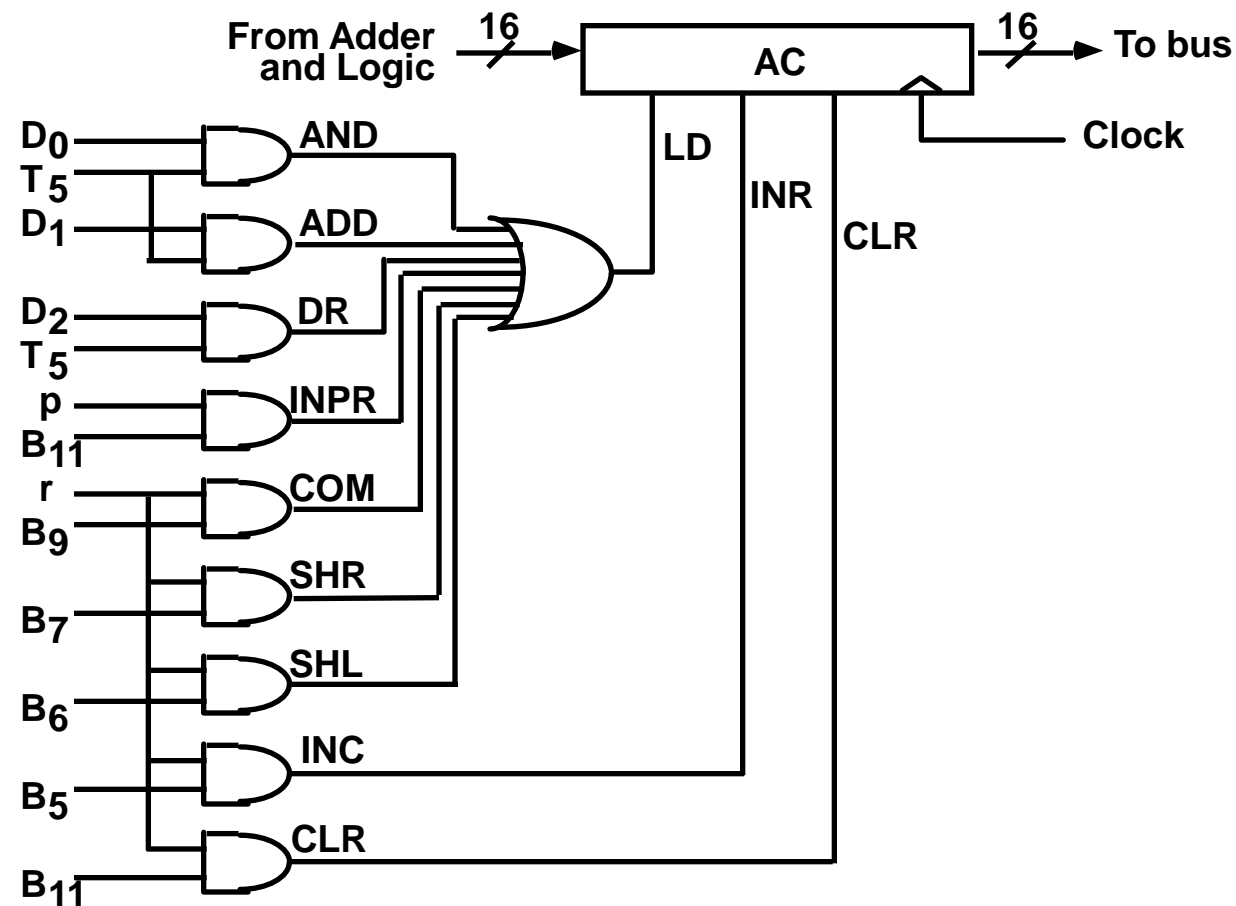

ALU (Adder & Logic Circuits)

One stage of Adder and Logic circuit

